

YAMAHA

TC-66

Stereo Cassette Tape Deck

Owner's Manual

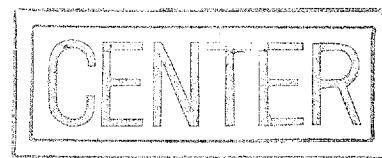

YAMAHA offers you thanks and congratulations on your choice of the TC-66 Stereo Cassette Tape Deck. Product of research directed at making the best possible audio performance available to the widest range of enthusiasts, the TC-66 sets new standards of operating convenience and audio quality in its class.

TC-66

CONTENTS

Features	3
Cautions — Read This Before Operating Your TC-66	4
Tape Care, Head Cleaning, and Head Demagnetization	5
Front Panel and Controls	6-7
Connection Diagram	8
Loading and Unloading Cassettes	9
Playback of Recorded Tape Cassettes	10
Recording of Program Sources	11
Absent Recording and Musical Alarm	12
Block Diagram and Specifications	13
Schematic Diagram	14
Trouble Shooting	15

TC-66

FEATURES

1. Vertical Format with Front Panel Controls

The vertical format of the TC-66 makes it easy to stack on — or under — other audio components, tuners, amplifiers, or receivers. Front controls make it easy to operate.

2. DOLBY* Noise Reduction System

Use of sophisticated DOLBY noise reduction circuitry suppresses tape hiss noise to where it should never bother you, giving a full 8dB increase in S/N ratio at frequencies above 5kHz.

3. Three-Way Tape Selector

To get the best from the whole range of available cassette tapes, three-way equalization switching is provided, giving precisely matched recording/playback characteristics for low-noise high output tape, chrome tape, and ferrichrome tape.

4. Full Auto Stop in All Operating Modes

A sensitive and quick-acting tape motion detector gives automatic shut-off and disengages tape drive as soon as the end of the tape is reached, whether in PLAY, REC, F FWD, or REW modes. This guards precious tapes and delicate drive mechanism from undue strain.

5. Large VU Meters

The large, easy-to-read VU meters give clear indication of recording and playback levels from -20 to +5dB, enabling accurate control of peak recording levels.

6. Cassette Chamber Illumination with Large Mirror

For the clearest possible indication of tape motion and the amount of tape left during recording or playback, full illumination is provided, with a large mirror.

7. Absent Recording or Musical Alarm Usage Possible

Purchase a timer unit, and the TC-66 will happily record an FM program in your absence, or wake you with the music of your choice in the morning.

**DOLBY is a trademark of Dolby Laboratories, Inc.*

CAUTIONS — READ THIS BEFORE OPERATING YOUR TC-66

- 1 The TC-66 is a high performance stereo cassette tape deck, with several special features. This manual is required reading if you are to get the best from your TC-66.
- 2 Do not drop or jar the TC-66, which is a precision instrument.
- 3 Avoid the following locations and conditions for the TC-66:
 - Exposure to direct sunlight, high humidity, and very dusty locations.
 - Particularly cold locations (directly in front of a cooler or air-conditioner outlet, etc.).
 - Exposure to stray magnetic fields (near TV sets, or other electrical appliances containing motors or transformers, etc.).
 - Locations subject to strong vibrations.
- 4 Do not use chemical solvents (such as benzene or alcohol) to remove traces of dirt. Wipe only with a soft, slightly damp cloth.
- 5 Open the transparent cassette chamber door *before* pushing the EJECT lever: a safety interlock ensures that a cassette cannot be ejected with the door closed. Excessive pressure on the EJECT lever with the door shut can damage the mechanism.
- 6 NEVER bring a screwdriver or other metallic item near the recording/playback head assembly: not only might the mirror-smooth surface be scratched, but the magnetic characteristics could be changed, giving increased noise and degraded audio performance.
- 7 Read carefully the section on Tape Care (facing page). The TC-66 cannot give top performance with poor quality and badly cared-for tape cassettes.
- 8 Be careful to observe any restrictions on tape recording and copying imposed by copyright laws.
- 9 Do not assume your TC-66 is faulty before checking the 'Trouble Shooting' list on Page 15 for common operating errors.

TC-66

TAPE CARE, HEAD CLEANING, AND HEAD DEMAGNETIZATION

CHOICE OF TAPE CASSETTE

You are recommended to buy a reputable brand of tape cassette. Cut-price brands can give very disappointing performance. Any of the following will be suitable with the TC-66.

TAPE Position Maker	LH	FeCr	CrO ₂
MAXELL	UD UDXL UDXLI		UDXLI
T.D.K.	SD ED AD		SA
AGFA	SHD		CHROME
BASF	LHSM	Ferrochrom	CRSM
Scotch	LOW NOISE MASTER		
SONY	HF	Duad	
FUJI	FX FX duo		

TAPE CARE - BEFORE AND AFTER

Before inserting a cassette, take up any slack in the tape by winding one of the spools with your finger or a pencil (as shown). Slack tape, or tape spillage, can become caught in the tape drive mechanism.

Store tape cassettes preferably in suitable cases, away from dust, damp, and heat. Always store with the tape fully wound one way or the other. Best results will be obtained if you remember to rewind the tape in the opposite direction once every three months or so, whether you listen to it or not.

If you wish to protect a recorded tape against unintentional erasure, break out the protective lug as shown in the diagram. Separate lugs protect the A and B sides. Once the lug has been broken out, it will be impossible to push the RECORD lever. If you later decide to erase the recording, you will have to cover the hole again with a small square of adhesive tape, etc.

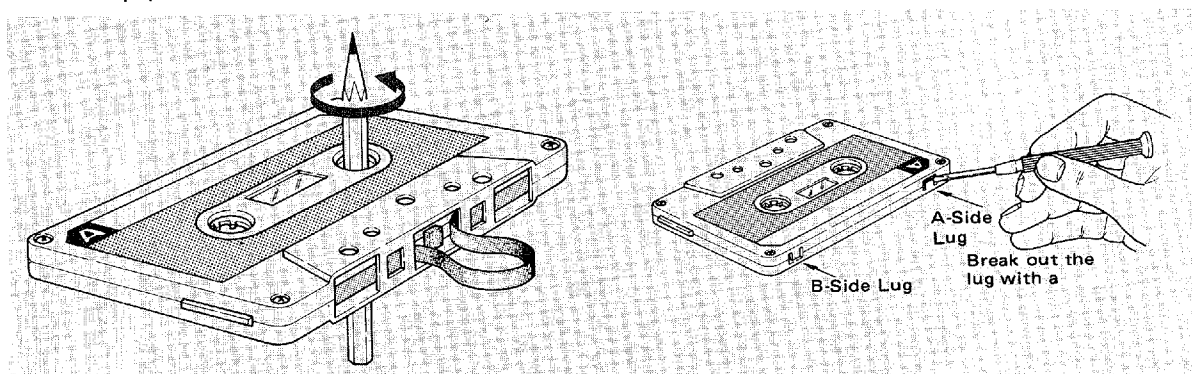

HEAD CLEANING AND DEMAGNETIZATION

The super-hard permalloy heads fitted to the TC-66 have inherently low distortion and high S/N ratio, but if they become dirty through the use of old tapes or the adhesion of atmospheric dust, etc., overall performance will deteriorate. From time to time one of the head-cleaning cassettes should be run through the TC-66 to restore it to its original condition. After considerable use the heads may need demagnetizing. Some dealers offer this service, or it is possible to purchase a demagnetizing unit. Follow the maker's instructions carefully if you use the latter.

TC-66

FRONT PANEL AND CONTROLS

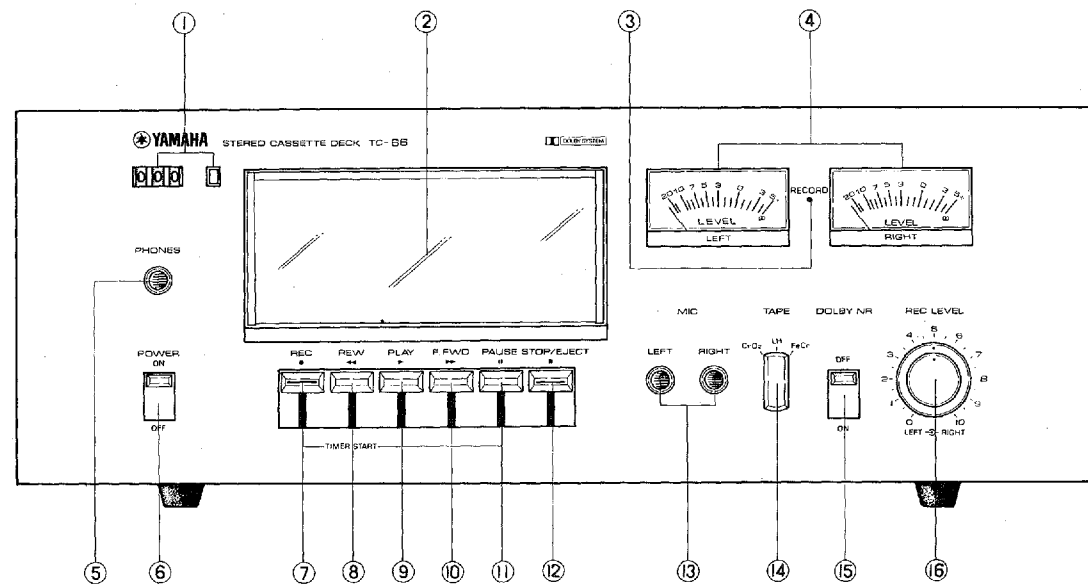

1 Tape Counter and Reset Button

Use the instant reset button to set the counter to '000' at the start of the tape or at the start of an individual recording or item of playback. This makes it easy to locate your starting point again. If you note the counter reading for the start of each item, it can save you time locating any particular item you may want to hear.

2 Cassette Door

Push this door up and out of the way when load-

ing and unloading cassettes: it will remain up. Press again lightly to release for full protection of the cassette from dust during play. Note that the cassette cannot be ejected while the door is closed.

3 RECORD Lamp

This indicator lamp lights when the REC lever has been depressed, and indicates that the TC-66 is in the recording mode.

4 LEVEL Meters

These give an accurate indication of the relative levels of sound during recording and playback. The \square mark indicates the DOLBY level. For all levels below this, the DOLBY circuits give a reduction in tape hiss.

5 PHONES Jack

Stereo headphones may be plugged into this jack to monitor the recording and the playback signals.

⑥ POWER ON/OFF Switch

Plug the AC mains plug into a power outlet socket, and raise this switch to the ON position. Power will be connected, and the light for the cassette chamber behind the cassette door, and the level meters, will light.

⑦ REC (●) Lever

This is the recording lever. Depress this lever first, and the level meters will indicate the levels of the signals connected. Recording can commence as soon as the levels have been adjusted properly and, subsequently, the PLAY (▶) lever has been depressed. The REC lever cannot be depressed if a cassette has not been loaded, or if the recording on the cassette has been protected from erasure by breaking out the protective lug(s) as mentioned on Page 5.

⑧ REW (◀◀) Lever

This is the fast rewind lever. Depress this lever when you want to wind the tape back to some previous point of the recording (or playback). It will return automatically when the Auto-Stop mechanism operates at the end of the tape. Do not attempt to go direct from REW to F FWD (▶▶) without first using the STOP/EJECT (■) lever to stop the tape transport.

⑨ PLAY (▶) Lever

This lever starts the tape transport. Depressing this lever alone initiates playback. If the REC lever has first been fully depressed, it initiates recording. The PLAY lever automatically returns when the Auto-Stop mechanism operates at the end of the tape.

⑩ F FWD (▶▶) Lever

This is the fast forward wind lever. Depress this lever to speed the tape forward. It will return automatically when the Auto-Stop mechanism operates at the end of the tape. Do not attempt to go direct from F FWD to REW (◀◀) without first using the STOP/EJECT (■) lever to stop the tape transport.

⑪ PAUSE (||) Lever

Depress this lever once, and playback (or recording) will be interrupted as the tape transport stops. Depress it a second time, and the original mode is resumed.

⑫ STOP/EJECT (■) Lever

Depress this lever to release all other levers and to stop the tape. Press slightly harder, and the cassette will be ejected. Note, however, that the cassette door must be open before the cassette can be ejected.

⑬ MIC Jacks, LEFT and RIGHT

These are the two microphone jacks (one each for left and right-hand channels when recording in stereo, which requires a pair of microphones). They can also be used for connecting microphone mixing amplifiers, and telephone conversation pick-ups, etc.

⑭ TAPE Selector Switch for CrO₂, LH, and Fe-Cr Tape

Select the appropriate position for the tape you are using (chrome, low noise high output, or ferrichrome) See Page 5.

⑮ DOLBY NR OFF/ON Switch

Record and playback with this ON to obtain the Dolby noise-reduction effect. Also leave it ON for pre-recorded music tapes which have been recorded via the Dolby system.

⑯ REC LEVEL (LEFT/RIGHT) Control

This sets the recording level for signals from MIC or LINE inputs. LEFT and RIGHT channel levels may be set independently for perfect balance, and then turned together for fade-in and fade-out techniques. The outer knob controls the right channel, and the inner, the left.

TC-66

CONNECTION DIAGRAM

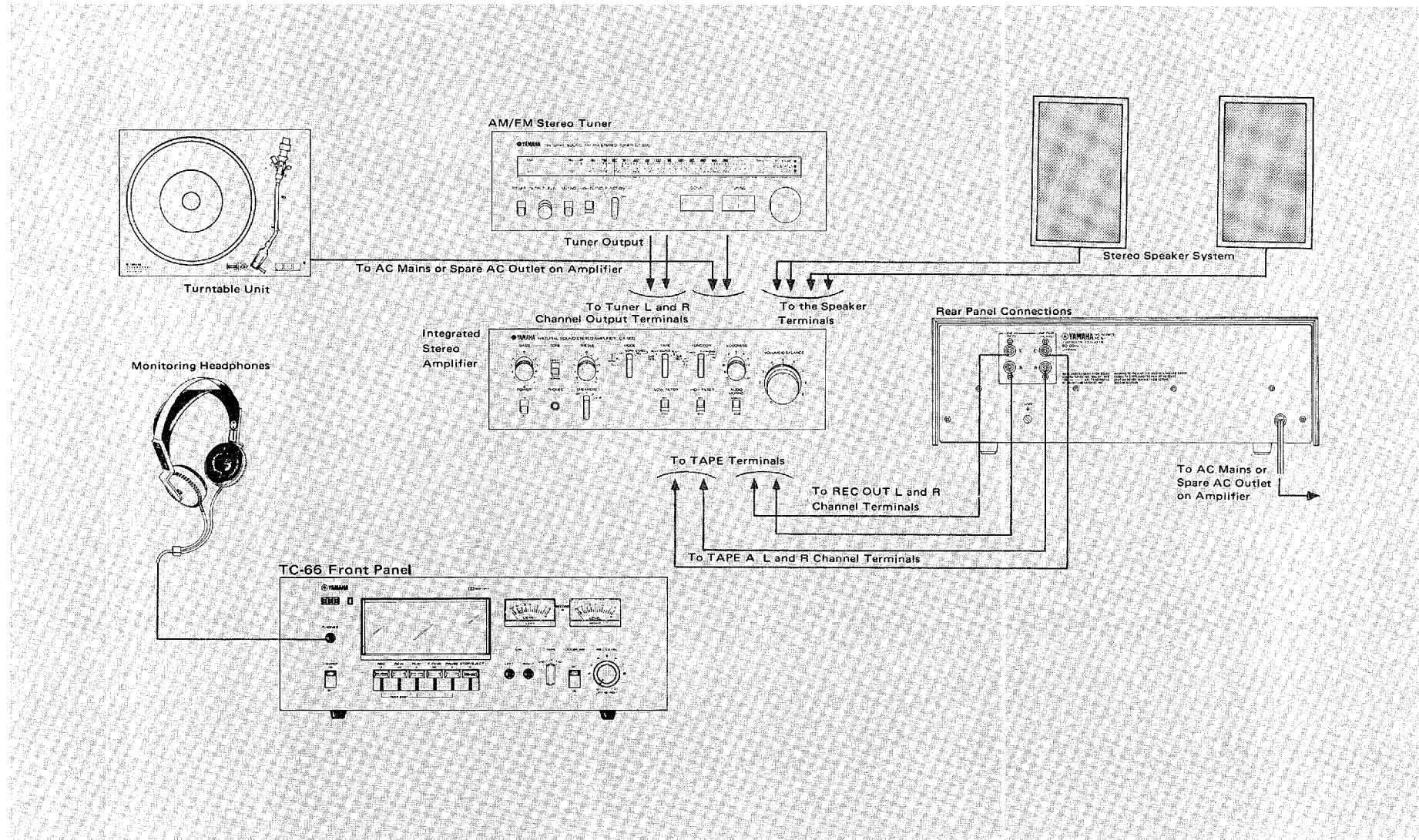

TC-66

LOADING AND UNLOADING CASSETTES

LOADING CASSETTES

1. First push the cassette chamber door up until it locks into position.
2. Hold the cassette with the exposed section of tape towards you, and with the side (A or B) which you wish to record or playback uppermost. Load the cassette horizontally into the cassette chamber until the cassette spool holes are over the drive spindles, and press downwards until the cassette audibly clicks into position.

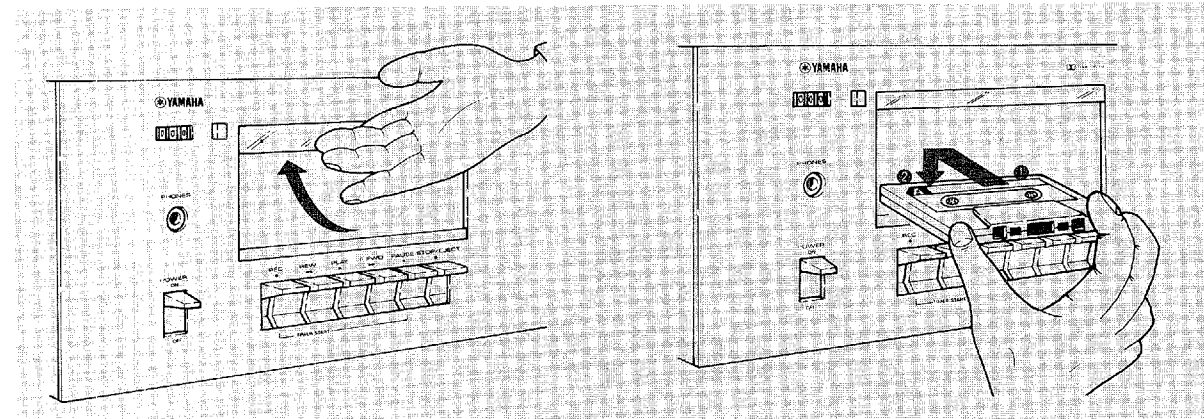

3. Before starting to record (or playback), once again push the cassette chamber door upwards. This will free the retaining lock, and the door will swing down to the closed position, protecting the cassette and the tape-drive mechanism from air-borne dust, etc.

UNLOADING CASSETTES

1. Depress the STOP/EJECT lever gently to stop the tape transport (unless the Auto-Stop mechanism has done this for you).

2. Push up the cassette chamber door until it locks into position again.
3. Depress the STOP/EJECT lever firmly, and the cassette will spring forward as it is ejected, as shown in the illustration.
4. Do not attempt to force ejection by increasing pressure on the STOP/EJECT lever *before* the door is open. Cassettes can only be ejected when the door is open. Excessive pressure will damage the TC-66.
5. It is better to fully wind the tape in one direction or the other before putting the cassette away.

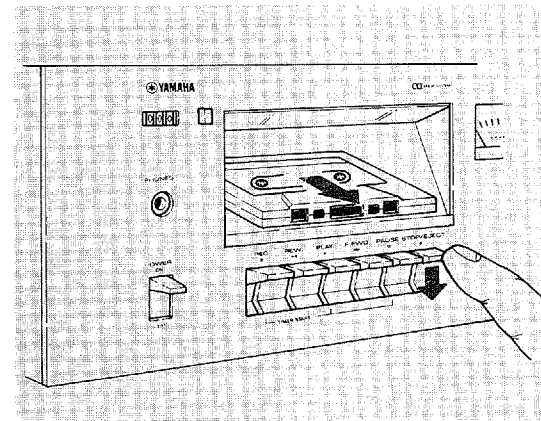

TC-66

PLAYBACK OF RECORDED TAPE CASSETTES

CONNECTING TO AN AMPLIFIER, ETC.

Refer to the connection diagram on Page 8. The same instructions apply whether you are connecting to an integrated (pre- plus power) amplifier, a receiver, or a separate preamplifier. Connect the LINE OUT (PLAY) terminals to the TAPE INPUT (or LINE IN) terminals on the rear of your amplifier. Be sure that you connect the L tape output to the L amplifier input, and R to R. Push all plugs fully and firmly home.

OPERATING SEQUENCE

1. Turn the POWER switch ON, as shown. The lamp in the cassette chamber, and the level meters, will illuminate.
2. Load the tape you want to play as directed in the section on Loading Cassettes (Page 9).

3. Turn the TAPE selector switch to the type of tape you are using, as shown.
4. If the tape has been recorded using the Dolby system, turn the DOLBY NR switch ON.
5. Depress the PLAY (▶) lever to start the tape, and playback will commence. Any adjustments to the volume level of the playback program must be made using the volume control of the amplifier, receiver, etc., through which it is being played.
6. You do not need to watch for the tape to end: as soon as the tape runs out, the Auto-Stop mechanism will stop the tape and reset the PLAY lever.
7. If you wish to stop playback at some point during the tape, press the STOP/EJECT lever.

FAST FORWARD WINDING

If you wish to start listening at some point part way through the tape, press the F FWD (▶▶) lever. If you have previously noted the tape counter number for the item you want, you can use the STOP/EJECT lever to stop the tape as soon as this number is reached.

FAST REWIND

If, on the other hand, you wish to wind back quickly to the start of a recording, or to repeat playback of something you have just heard, use the REW (◀◀) lever. If you want to hear from the beginning of the tape, just leave the Auto-Stop mechanism to reset the REW lever at the end of the rewinding.

INSTANTANEOUS PAUSE LEVER

One touch to the PAUSE lever instantly stops the tape during playback. Do not, however, use the PAUSE lever instead of the STOP/EJECT lever for lengthy stops. Keep it for brief pauses.

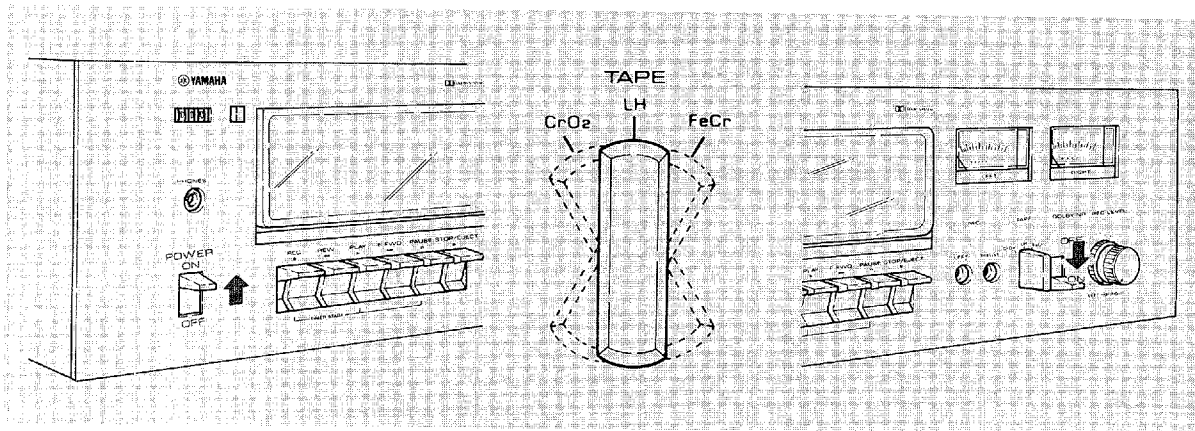

BEFORE YOU START RECORDING

Refer to connection diagram on Page 8 for the connections to be made to an integrated amplifier. They are exactly the same for receiver or preamplifier. Connect the LINE IN (REC) terminals to the REC OUT (TAPE) terminals on the rear of your amplifier. Be sure that you connect the L tape input to the L amplifier REC OUT terminal, and the R input to the R output terminal. Push all plugs fully and firmly home.

OPERATING SEQUENCE

1. Refer to Page 9 on Loading Cassettes, and load the cassettes with the side you wish to record uppermost.
2. Turn the TAPE selector switch to the type of tape you are using.
3. Turn the DOLBY NR switch ON (unless you are recording for someone who will not be able to listen via Dolby circuits).
4. Before you start, set the tape counter to '000.' This will enable you to find the start of the recording again quickly and easily.
5. Switch your amplifier ON, and put the program source you wish to record ON too (whether record, radio broadcast, or other tape recording, etc.). Switch the amplifier to give the required REC OUT signal source.
6. Switch the POWER ON. The cassette chamber and the level meters will light up.
7. Firmly depress the REC lever and watch the level meters. Adjust the REC LEVEL control for the L and R-hand channels for the correct balance and level. The best setting will often have the meter needles usually varying between about -3 VU and 0 VU, very occasionally flicking above 0 VU on extremely loud passages. The best setting will vary with different kinds of tape: your ears will be the best judge.
8. With the REC lever still down, depress the PLAY lever, and recording will begin.
9. When you have finished recording, press the STOP/EJECT lever.
10. If the recording has still not finished when the tape ends, the Auto-Stop mechanism will stop the tape transport and reset the REC and PLAY levers.
11. To continue recording on the other side of the cassette, follow the instructions on Page 9 for unloading, turn it over, and reload before repeating steps (8) and (9). (You should not need to readjust the REC LEVEL for the same program.)
12. Use the PAUSE lever to interrupt recordings to cut out unwanted announcements. Smooth, instant starts to recordings can also be obtained by first depressing the PAUSE lever, then the REC and PLAY levers. As soon as the REC LEVEL has been correctly set, a second touch to the PAUSE lever enables recording to start at once.

ERASING RECORDINGS

When you wish to re-record a cassette, the previous recording will automatically be erased as the new recording is made, unless the protective lugs have been broken out (see Page 5), when recording will be impossible until the lug holes are covered over. If you wish only to erase the previous recording, set up as for a re-recording, but run through the tape with REC LEVEL control set at the zero (minimum) position.

TC-66

ABSENT RECORDING AND MUSICAL ALARM

With the purchase of a timer switch, your TC-66 will function either to record programs during your absence, or as a musical alarm clock, awakening you with taped music at the time of your choice.

ABSENT RECORDING

1. Connect the TC-66, the timer, and the tuner/amplifier (or receiver) as shown. If your amplifier does not have the necessary spare AC outlets for the arrangement shown, use adaptors so that the timer can control all the units similarly.
2. Temporarily set the timer so that it switches the current ON. If it has a bypass switch, use that.
3. Turn and leave the POWER switches of each unit ON.
4. Select and tune in carefully the station which you intend to record.
5. Load the cassette you intend to record, depress the REC lever, and set the REC LEVEL, preferably for the same kind of program material as the one you are to record.
6. Depress both PLAY and PAUSE lever with the timer (or bypass switch) OFF.
7. Set the timer to be ON for the period during which you want to record, and leave it to switch on the electrical power and automatically commence recording at that time, when the PAUSE lever will disengage.
8. Be very careful to set the duration of the timer ON period for longer than the total length of tape: for instance if you have loaded a C-120 tape (which give 60 minutes per side), set the timer to run for 10 or 15 minutes longer than the hour, even if the program you wish to record will take less than an hour. This is to ensure that the Auto-Stop mechanism works before the electrical power is cut off, protecting the drive capstan from undue strain.

MUSICAL ALARM

Set up the timer exactly as for absent recording with the following exceptions:

1. Use a pre-recorded tape.
2. Do NOT depress the REC button.
3. Set the playback volume beforehand to an acceptable level by adjusting the amplifier volume control.

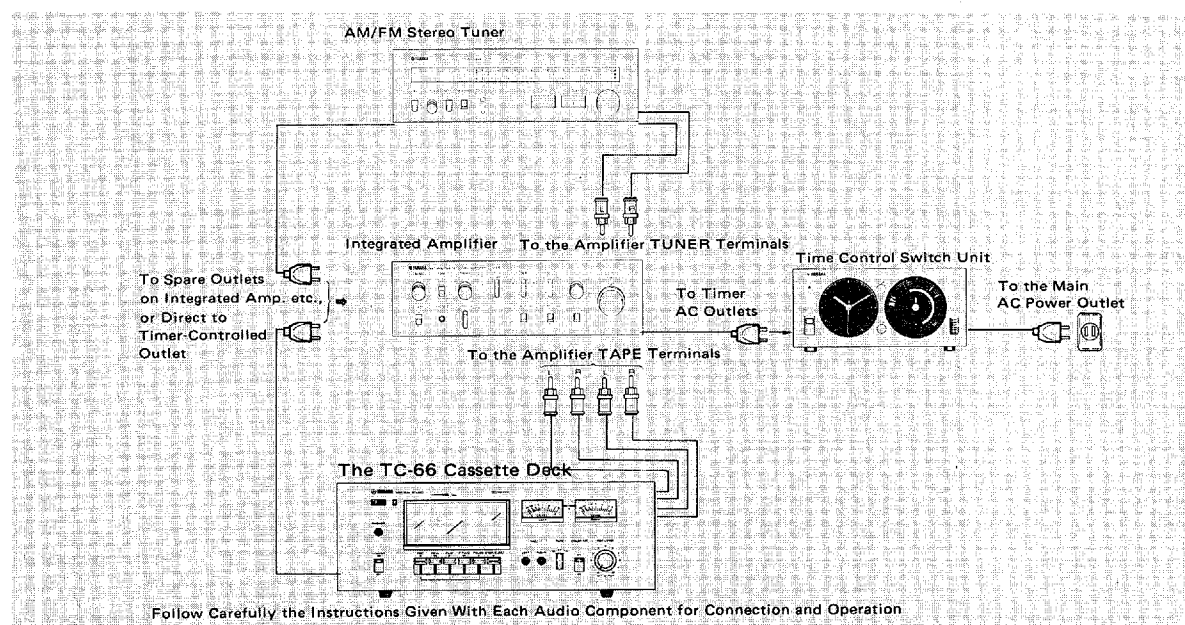

TC-66

BLOCK DIAGRAM AND SPECIFICATIONS

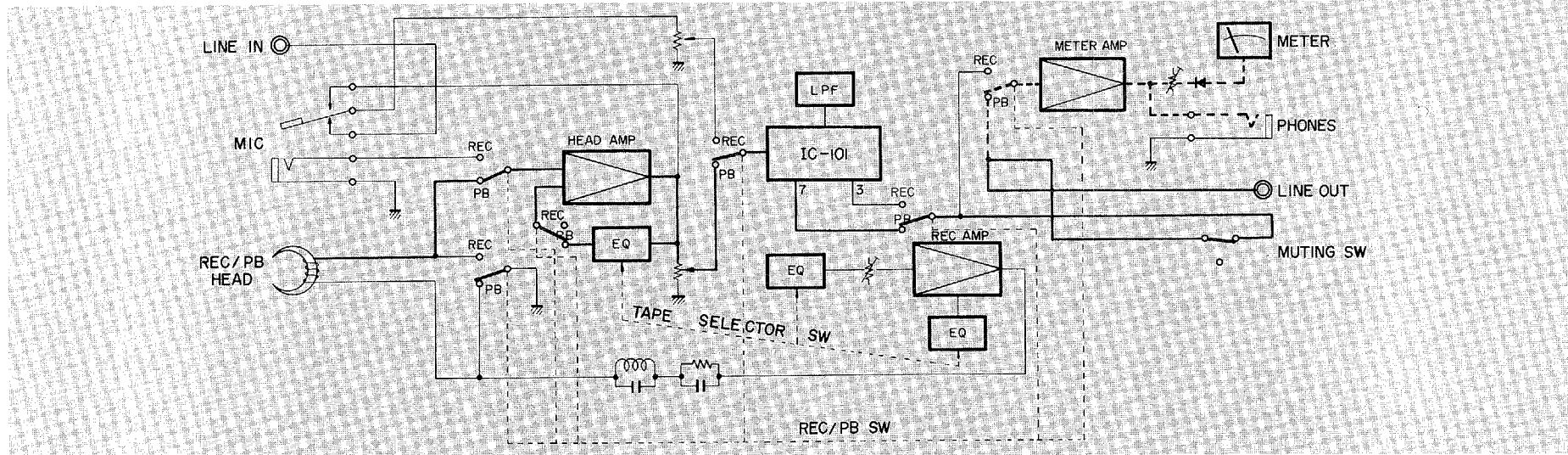

SPECIFICATIONS

Track Configuration

4-track 2-channel stereo cassette deck

Mechanical

Wow and flutter

Less than 0.07% wrms (JIS)

Tape speed

Less than 0.2% (DIN)

Rapid transport (F FWD/REW)

4.8 cm/sec (1-7/8 ips)

Within 90 sec (for C-60 cassette)

Electrical

REC/PB frequency response

30 Hz to 13 kHz (Low noise high output tape)

30 Hz to 15 kHz (Fe-Cr and CrO₂ tape)

Input sensitivity/impedance

LINE: 50 mV/100 kΩ

MIC (DIN): 0.5 mV/5 kΩ

Signal-to-Noise Ratio

53 dB

Dolby OFF

8 dB improvement above 5 kHz (LH tape, with

Dolby ON

JIS auditory compensation filter)

Overall distortion

Less than 1.5% (1 kHz, 0 VU, LH tape)

Channel separation

Better than 30 dB (1 kHz)

Output level/impedance

LINE: 370 mV/50 kΩ (0 VU)

PHONE: 1.6 mW/8 Ω (0 VU)

5 mW/150 Ω

General

Semiconductors used

18 Transistors, 4 ICs, and 21 Diodes

Power consumption

12 Watts

Power supplies

120 V, 60 Hz Canada & U.S.A.

Dimension (W x H x D)

435 x 160 x 334 mm

17-1/8" x 6-1/4" x 13-1/8"

Weight

8 kg (17 lb 10 oz)

Accessories

Connecting cable with pin-jack plugs

Specifications subject to change without notice.

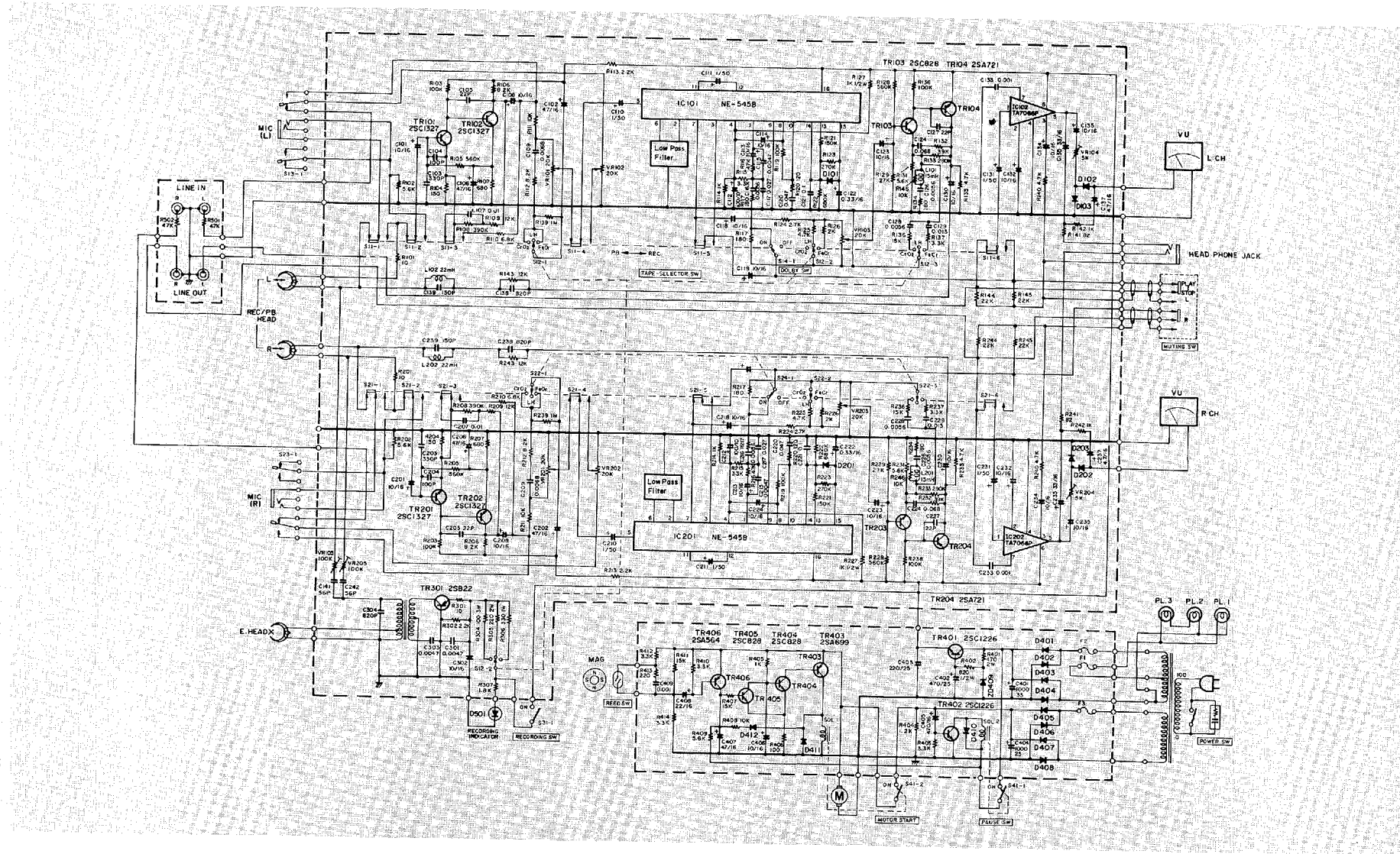

Before assuming that your TC-66 is malfunctioning, check the following trouble-shooting list, which details corrective action you can take yourself, without having to call a service representative.

Fault	Cause	Cure
Tape does not move	Mains plug not properly plugged in, or POWER switch OFF. The tape is fully wound on. The PAUSE switch is down.	Plug in firmly, and make sure that POWER is ON. Rewind or turn the cassette over. Press again to release.
REC lever cannot be depressed.	No cassette has been loaded. The protective lugs to stop accidental erasure have been broken out.	Load a cassette Cover the lug-holes with tape if you no longer wish to preserve the recording.
The sound becomes unclear (blurred).	Dirty recording/playback head.	Run a 'cleaning tape' cassette through to clean the head.
The playback sound becomes 'wavery.'	The tape itself has become distorted (stretched).	Replace with new tape
The playback sound becomes distorted.	The recording itself contained distortion.	Nothing can be done if the tape recording is distorted. Try repeating with a different tape.
Recordings are distorted.	The REC LEVEL was too high.	Turn the REC LEVEL down, checking the recording input signal level with the level meters.
Noise is obtrusive.	The heads are magnetized. Poor quality tape was used. Connecting cable not properly plugged in. External interference	Demagnetize with head demagnetizer. Replace with good tape. Check and make good the connections for input/output terminals. Increase the distance between the TC-66 and other electrical equipment (TV, fluorescent lights etc.).
No sound on playback.	Connections faulty.	Check and make good connections.
Recording is impossible via LINE IN (REC) terminals	Microphone jacks have been left plugged in.	Always remove the microphone jacks when not using the microphones.
Wow and flutter (a 'wavering' in the sound) are large.	Dirt on capstan, pinch roller, etc. The tape is unevenly wound in the cassette.	Run a 'cleaning tape' cassette through to clean them. Rewind the tape completely once, using either F FWD or REW.
The tape jams during recording or playback.	Tape slackness or spillage may have cause the tape to become wound around the capstan, etc. Defective tape cassette.	Remove, and wind up the slack with a pencil or your finger, rotating the hub. Replace.



SINCE 1887  **YAMAHA**
NIPPON GAKKI CO., LTD. HAMAMATSU, JAPAN

Printed in Japan 773